

- N. B. :
- (1) Question No. 1 is compulsory.
 - (2) Attempt any four questions out of remaining six questions.
 - (3) Use drawing sheets only for answering.
 - (4) All dimensions in figure are in mm.
 - (5) Use your judgement for any unspecified dimensions.
 - (6) Use only first angle method of projections.

1. Figure below shows Front view and Top view of an object. Draw the following views.

- (a) Sectional F.V. along A-A
- (b) Top view
- (c) Sectional R.H.S.V. along B-B
- (d) Insert at least 8 major dimensions.

5
4
5
1

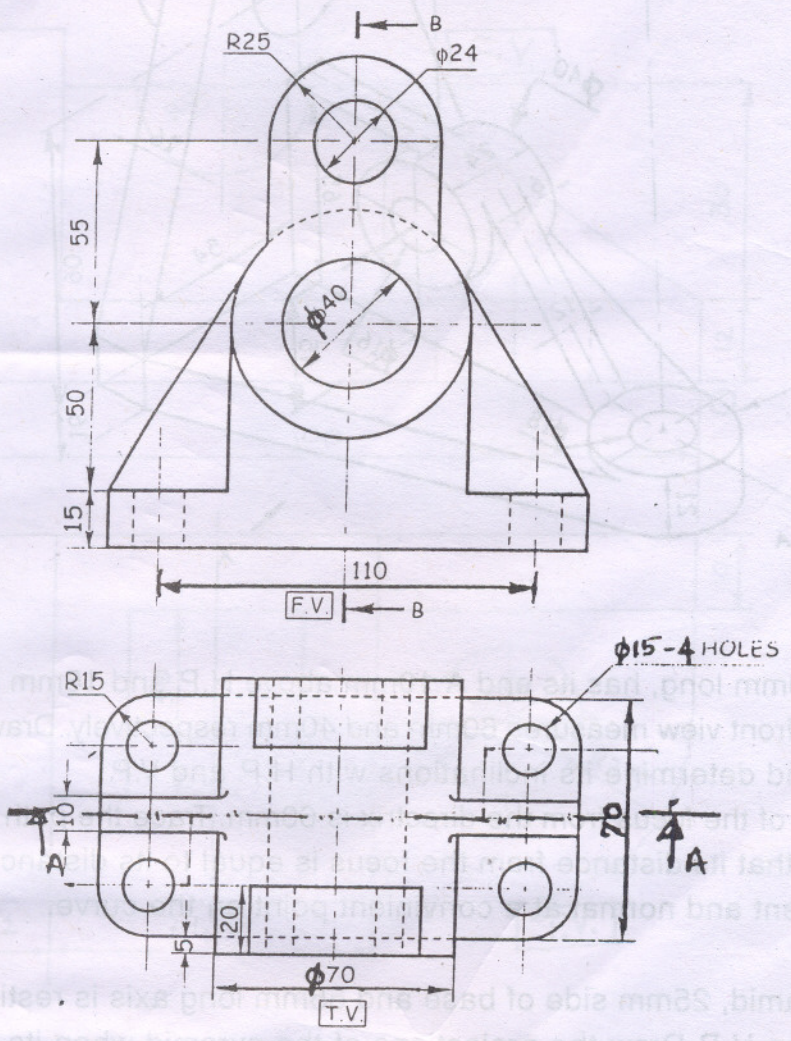

2. Figure shows the pictorial view of a machine part. Draw using full scale.

- (a) Sectional front view along A-A
- (b) Top view
- (c) Left hand side view

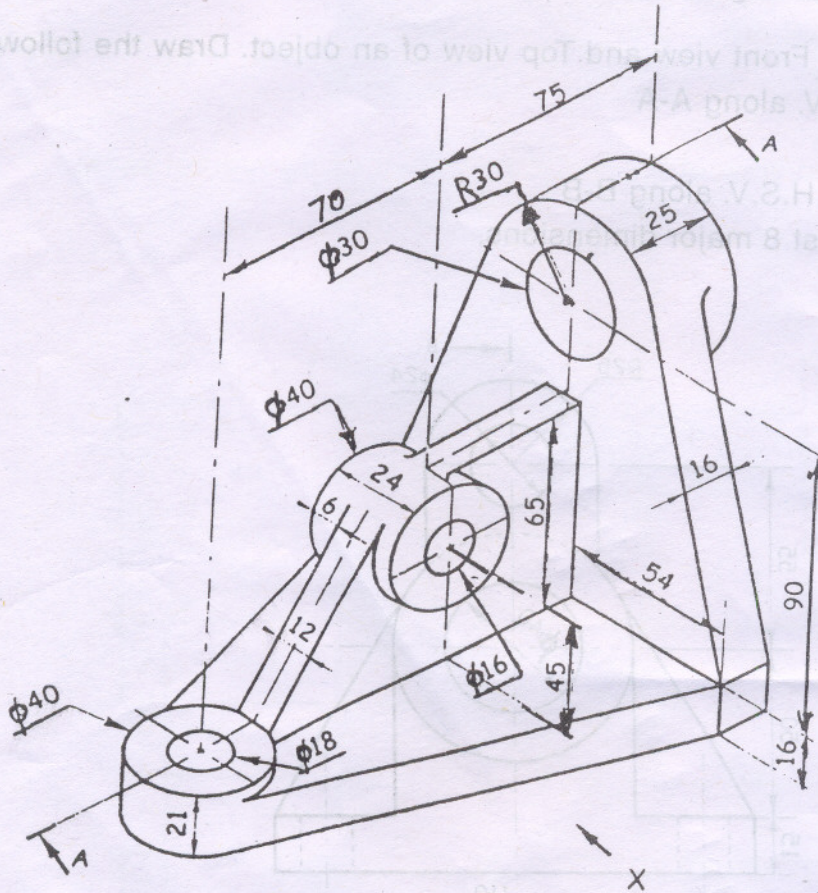

- 3. (a) A Line AB 70mm long, has its end A 10mm above H.P. and 15mm in front of V.P. its top view and front view measures 60mm and 40mm respectively. Draw the projections of the line and determine its inclinations with H.P. and V.P. 8
- (b) The distance of the focus from the directrix is 60mm. Trace the path of a point which moves such that its distance from the focus is equal to its distance from directrix. Draw a tangent and normal at a convenient point on the curve. 7
- 4. A hexagonal pyramid, 25mm side of base and 55mm long axis is resting on one of its triangular faces on H.P. Draw the projections of the pyramid when its base edge is in H.P. & is inclined at 45° to the V.P. 15

6. (a) A cube of 40mm edge stands on one of its faces on H.P. with a vertical face making 11 45° to V.P. A horizontal hole of 30mm diameter is drilled centrally through the cube such that the hole passes through the apposite vertical edges of the cube. Obtain the development of the lateral surface of the cube with the hole.

(b) Draw two views of the following :—

- (i) Hexagonal nut
- (ii) Wing nut.

4

7. (a) Draw an isometric view of the following object using natural scale.

11

