

(2 Hours)

[Total Marks : 60

- N.B.: (1) Question No.1 is compulsory.
(2) Attempt any **three** questions from Q.2 to Q.6
(3) Use suitable data wherever required.
(4) Figures to **right** indicate full marks.

1. Attempt any five of the following:

- (a) Fringes of equal thickness are observed in a thin glass wedge of R.I-1.52. The fringe spacing is 1mm and wavelength of light used is 5893\AA . Calculate the angle of the wedge.
- (b) What is meant by diffraction? State its types and differentiate them.
- (c) The core diameter of multimode step Index fibre is $50\mu\text{m}$. The numerical aperture is 0.25. Calculate the no. of guided modes at an operating wavelength of $0.75\mu\text{m}$.
- (d) Differentiate spontaneous and stimulated emission process related to laser operation.
- (e) How is phase difference between two A.C. signals measured by CRO?
- (f) What is De-Broglie wavelength of an electron which has been accelerated from rest through a potential difference of 100V?
- (g) How can the 'Maglev' train have very high speed?
2. (a) Show that the diameter of Newton's n^{th} ring is directly proportional to square root of ring number. In a Newton's ring pattern one of the dark ring due to light of wavelength 7000\AA is found to coincide with the dark ring of next order due to 5000\AA . If the radius of curvature of the lens is 148.8cm. Find the diameter of the overlapping dark ring. 8
- (b) Define: (i) Numerical aperture 6
(ii) Total internal reflection
(iii) Acceptance angle
Derive the expression for numerical aperture of step index fibre.
3. (a) What is Holography? Explain the construction and reconstruction of Hologram with neat diagrams. 8
- (b) Why are the fringes in Wedge shaped film straight? Derive the conditions of maxima and minima for interference in wedge shaped film. 7

[TURN OVER

4. (a) A diffraction grating used at normal incidence gives a yellow line ($\lambda=6000\text{\AA}$) in a certain spectral order superimposed on a blue line ($\lambda=4800\text{\AA}$) of next higher order. If the angle of diffraction is $\sin^{-1}(3/4)$, Calculate the grating element. 5
- (b) Derive Schrodingers time-independent wave equation. 5
- (c) Differentiate Type-I and Type-II super conductor. 5
5. (a) The visible spectrum ranges from 4000\AA to 7000\AA . Find the angular breadth of the first order visible spectrum produced by a plane grating having 6000 lines/cm when light is incident normally on the grating. 5
- (b) Show that the energy of an electron in a box varies as the square of the natural number. 5
- (c) What are carbon-nano tubes? Explain its properties? 5
6. (a) With single slit electron diffraction, prove Heisenberg's uncertainty principle. 5
- (b) Explain the principle, construction and working of CRT with neat diagram. 5
- (c) Explain the top down approach and bottom up approach to prepare nanomaterials. 5

18 Nov. 2015

QP Code : 5801

[Total Marks : 80]

(3 Hours)

- N.B. (1) Question No.1 is compulsory.
 (2) Attempt any three questions out of the remaining five questions.
 (3) Figures to right indicate full marks.

1. (a) Evaluate $\int_0^2 x^2 (2-x)^3 dx$ [3]
- (b) Solve $\frac{d^3 y}{dx^3} - 6 \frac{d^2 y}{dx^2} + 11 \frac{dy}{dx} - 6y = 0$ [3]
- (c) Prove that $E = 1 + \Delta$ [3]
- (d) Solve $\left[y \left(1 + \frac{1}{x} \right) + \cos y \right] dx + (x + \log x - x \sin y) dy = 0$ [3]
- (e) Change to polar coordinates and evaluate $\int_0^a \int_0^{\sqrt{a^2-x^2}} (x^2 + y^2) dy dx$ [4]
- (f) Evaluate $\int_0^1 \int_0^x xy dy dx$ [4]
2. (a) Solve $\frac{dy}{dx} + \frac{4x}{x^2+1} y = \frac{1}{(x^2+1)^3}$ [6]
- (b) Change the order of integration and evaluate $\int_0^2 \int_{\sqrt{2x}}^2 \frac{y^2 dx dy}{\sqrt{y^4 - 4x^2}}$ [6]
- (c) Prove that $\int_0^{\pi/2} \frac{\log(1+a \sin^2 x)}{\sin^2 x} dx = \pi [\sqrt{a+1} - 1]$ $a > -1$ [8]
3. (a) Evaluate $\int_0^1 \int_0^{1-y} \int_0^{1-x-y} \frac{1}{(x+y+z+1)^3} dz dy dx$ [6]
- (b) Find by double integration the area enclosed by the curve $9xy = 4$ and the line $2x + y = 2$ [6]

[TURN OVER

- (c) Using method of Variation of Parameter solve $\frac{d^2 y}{dx^2} + a^2 y = \sec ax$ [8]
4. (a) Find the perimeter of the cardioide $r = a(1 + \cos\theta)$ [6]
 (b) Solve $(D^2 + 4)y = \cos 2x$ [6]
 (c) Apply Runge-kutta Method of fourth order to find an approximate value of y for $\frac{dy}{dx} = \frac{1}{x+y}$ with $x_0 = 0, y_0 = 1$ at $x = 1$ taking $h = 0.5$ [8]
5. (a) Solve $(y - xy^2)dx - (x + x^2y)dy = 0$ [6]
 (b) Using Taylor Series Method obtain the solution of following differential equation $\frac{dy}{dx} = 1 + y^2$ with $y_0 = 0$ when $x_0 = 0$ for $x = 0.2$ [6]
 (c) Find the approximate value of $\int_0^6 e^x dx$ by i) Trapezoidal Rule, ii) Simpson's 1/3rd Rule, iii) Simpson's 3/8th Rule [8]
6. (a) A resistance of 100 ohms and inductance of 0.5 henries are connected in series with a battery of 20 volts. Find the current at any instant if the relation between L, R, E is $L \frac{di}{dt} + Ri = E$. [6]
 (b) $\iint y dx dy$ over the area bounded by the $x = 0, y = x^2, x + y = 2$ [6]
 (c) Find the volume bounded by the paraboloid $x^2 + y^2 = az$ and the cylinder $x^2 + y^2 = a^2$ [8]

App. Chemistry - II

Q.P. Code : 5816

(2 Hours)

[Total Marks : 60

- N.B. :** (1) Question No. 1 is compulsory.
 (2) Attempt any three questions out of the remaining five questions.
 (3) All questions carry equal marks.
 (4) Figures to the right indicate full marks.
 (5) Atomic weights : H = 1, C = 12, N = 14, O = 16, S = 32, Cl = 35.5

1. Answer any five of the following :-

15

- What is 'Oxidation corrosion' ? Why do gold and platinum metal not get corroded in atmospheric oxygen ?
- Give composition, properties and uses of German silver.
- What is 'cracking' of heavy oil ? Mention any four advantages of catalytic cracking over thermal cracking.
- Explain 'prevention of waste' principle in Green Chemistry.
- What are composite materials ? Mention any four characteristics of composite materials.
- What is metal cladding ? How is 'alclad' obtained ?
- 1.5g of a coal sample was burnt in a combustion apparatus and the products of combustion were collected in previously weighed KOH bulb and CaCl₂ tube. The increase in weights of KOH bulb and CaCl₂ tube were found to be 3.92g and 1.25g respectively. Calculate percentage carbon and hydrogen in the sample.

2. (a) How do the following factors affect the rate of corrosion ?

6

- Relative areas of anodic and cathodic parts
- Purity of metal
- pH of medium

(b) What is meant by 'Knocking' in internal combustion engine ? Define Octane number. Name any two anti-knock agents.

5

(c) Calculate percentage atom economy for the following reaction with respect to cinnamaldehyde.

4

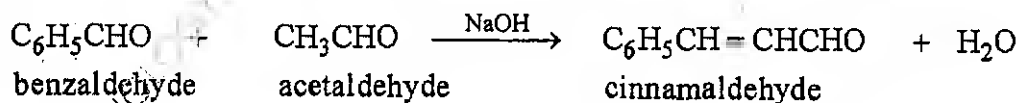

3. (a) A gaseous fuel has the following composition by volume.

6

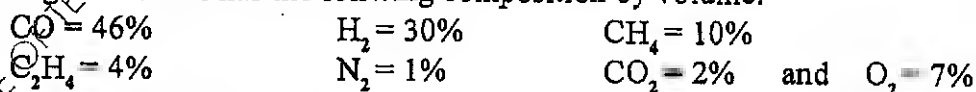

Calculate volume and weight of air required for complete combustion of 1m³ of fuel (Mol. wt. of air = 28.949)

[TURN OVER

- (b) Explain conventional and greener route of production of Indigo dye. Highlight the green chemistry principle involved. 5
- (c) Explain Galvanic corrosion with the help of a suitable example and diagram. 4
4. (a) What is powder metallurgy? List various steps involved in powder metallurgy. Mention the aim of each step. 6
- (b) With the help of a diagram and electrode reactions, explain mechanism of electrochemical corrosion of iron by hydrogen evolution, in acidic medium. 5
- (c) Explain 'sandwich panel' type layered structural composites, with a suitable diagram. Mention their application. 4
5. (a) With a suitable diagram, explain process of refining of petroleum. Name any two fractions obtained. 6
- (b) How are plain carbon steels classified based on carbon content? What are the drawbacks of plain carbon steels? 5
- (c) Discuss influence of any two chemical factors on adhesive action. 4
6. (a) Define 'Paint'. Mention any four constituents of paint with their functions. 5
- (b) A sample of coal has the following composition by mass : 5
- | | | |
|----------|----------|---------------|
| C = 70%, | H = 10%, | O = 4% |
| S = 2% | N = 2% | and Ash = 12% |
- Calculate Gross and Net calorific value using Dulong's formula.
- (c) Distinguish between Brass and Bronze. 5
-

F·E (Sem II) CBGS

Structured Programming Approach

QP Code : 5823

7/12/2015

(3 Hours)

[Max Marks 80

N.B.

- (1) Question no. 1 is compulsory.
- (2) Attempt any 3 from the remaining questions.
- (3) Assume suitable data if necessary.
- (4) Figures to right indicate full marks.

- | | | |
|-------|--|----|
| Q1(a) | What do you mean by register and static storage class. Explain with example. | 4 |
| Q1(b) | State any 2 library function in string.h with example. | 4 |
| Q1(c) | Explain any 2 bitwise operators in C with example | 4 |
| Q1(d) | Explain the difference between while and do ..while loop. | 4 |
| Q1(e) | Explain pow() ,abs() , isalnum() and ceil() function. | 4 |
| Q2(a) | What is the use of structure? Explain with an example. Also explain the concept of nested structures. | 10 |
| Q2(b) | Write a program in C to find minimum number in an array. | 10 |
| Q3(a) | Write a program which will accept 2 dimensional square matrix and find out transpose of it. Program should not make use of another matrix. | 10 |
| Q3(b) | With reference to parameter passing to function explain call by value and call by reference with an example | 10 |
| Q4(a) | Write a program to search a number within the array. | 10 |
| Q4(b) | What do you mean by Recursion? write a program which will add first n natural numbers using recursion . | 10 |
| Q5(a) | Write a program in C to implement following summation of series upto n terms. | 10 |
| | $1 - x^2/2! + x^4/4! - x^6/6! + x^8/8! - \dots$ | |
| Q5(b) | What do you mean by FILE ? What are the different functions available to read data from file ? Specify the different modes in which file can be opened along with syntax. | 10 |
| Q6(a) | Generate the following pattern of digits using nested loops | 10 |
| | (i) | |
| | 1 | |
| | 2 3 2 | |
| | 3 4 5 4 3 | |
| | 4 5 6 7 6 5 4 | |
| | (ii) | |
| | * | |
| | * * | |
| | * * * | |
| | * * * * | |
| | * * * * * | |
| Q6(b) | Write a function to check whether the given number is Armstrong number or not. An Armstrong number is a number in which sum of cube of its all digits is equal to number itself. For example 371 is an Armstrong number, since $3^3 + 7^3 + 1^3 = 371$. Use above function to generate all Armstrong numbers between 1 to 1000. | 10 |

NB:

- 1) Question No 1 is compulsory.
- 2) Answer any Three from the remaining Five.
- 3) Use first angle projection method only.
- 4) Figures to the right indicate full marks.

- Q1 a) Figure given below shows two views of an object. Draw the following views to full scale:-
- i) Front view 5
 - ii) Left hand Side view 4

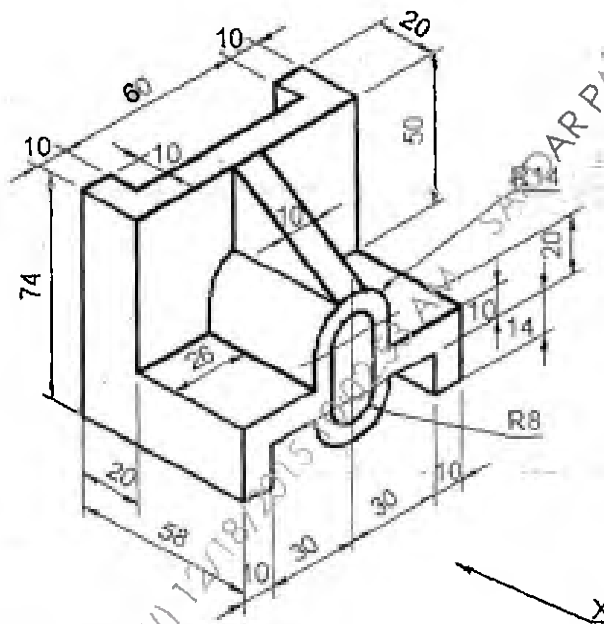

- b) Draw an involute of a circle of 40 mm diameter. Also draw the normal and tangent to the curve at a point 80 mm from the centre of the circle. 6

- Q2 a) The front view of a line AB 80 mm long, measures 60 mm. The end A is 15 mm in front of VP and 10 mm above HP. The end B is in third quadrant. Draw the projections of the line, if the line is inclined 30° to HP. Also find the inclination of line with VP. 7

[TURN OVER

- Q4 a) A square prism, edge of base 35 mm and axis length 70mm, is resting on HP on one of its base edges and the axis makes an angle 40° to HP and Parallel to VP. Draw its projections. 6
- b) Draw the isometric view of the following using the natural scale 9

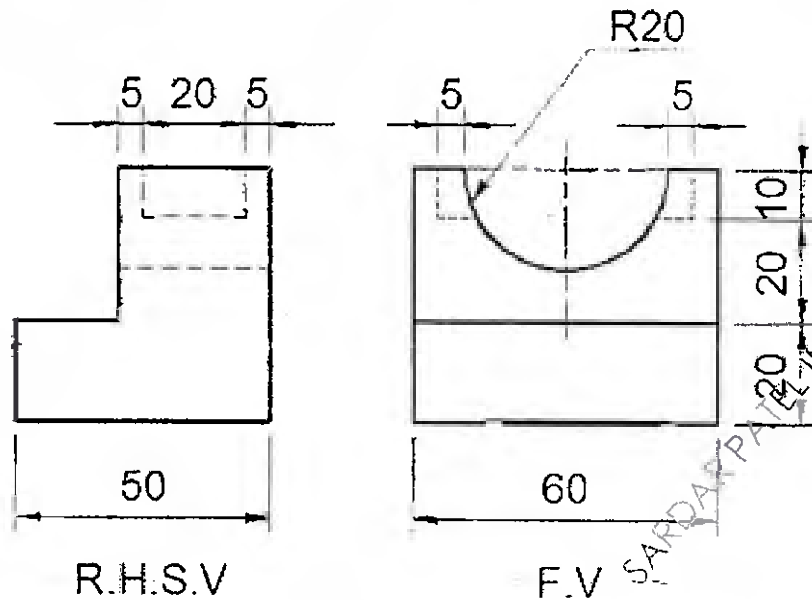

- Q5 A pentagonal pyramid has an edge of base in the H.P. and inclined at an angle 30° to the V.P. while the triangular face containing that edge makes an angle of 45° with the H.P. Draw the projections of the pyramid when the apex is nearer to the observer. The length of the side of the base of the pyramid is 35 mm and axis 70 mm. 15
- Q6 A cylinder, 40 mm diameter and 60 mm long is resting on its base on HP. It is cut by a section plane perpendicular to VP, inclined at 45° to HP and passing through the midpoint of the axis. Draw the front view, sectional top view and true shape of the section. Also develop the lateral surface of the cut cylinder. 15