

(OLD COURSE)

QP Code : MV-17758

(3 Hours)

[Total Marks : 75]

Instructions:

- Question No.1 is compulsory.
- Attempt any 4 from remaining 6 questions.
- All dimensions in fig. are in mm.
- Use **first Angle Method** of projection only.

Use your judgment for unspecified dimensions.

Q1 Draw the sectional front View A-B, TV and Left Hand Side View from the given two views. 15

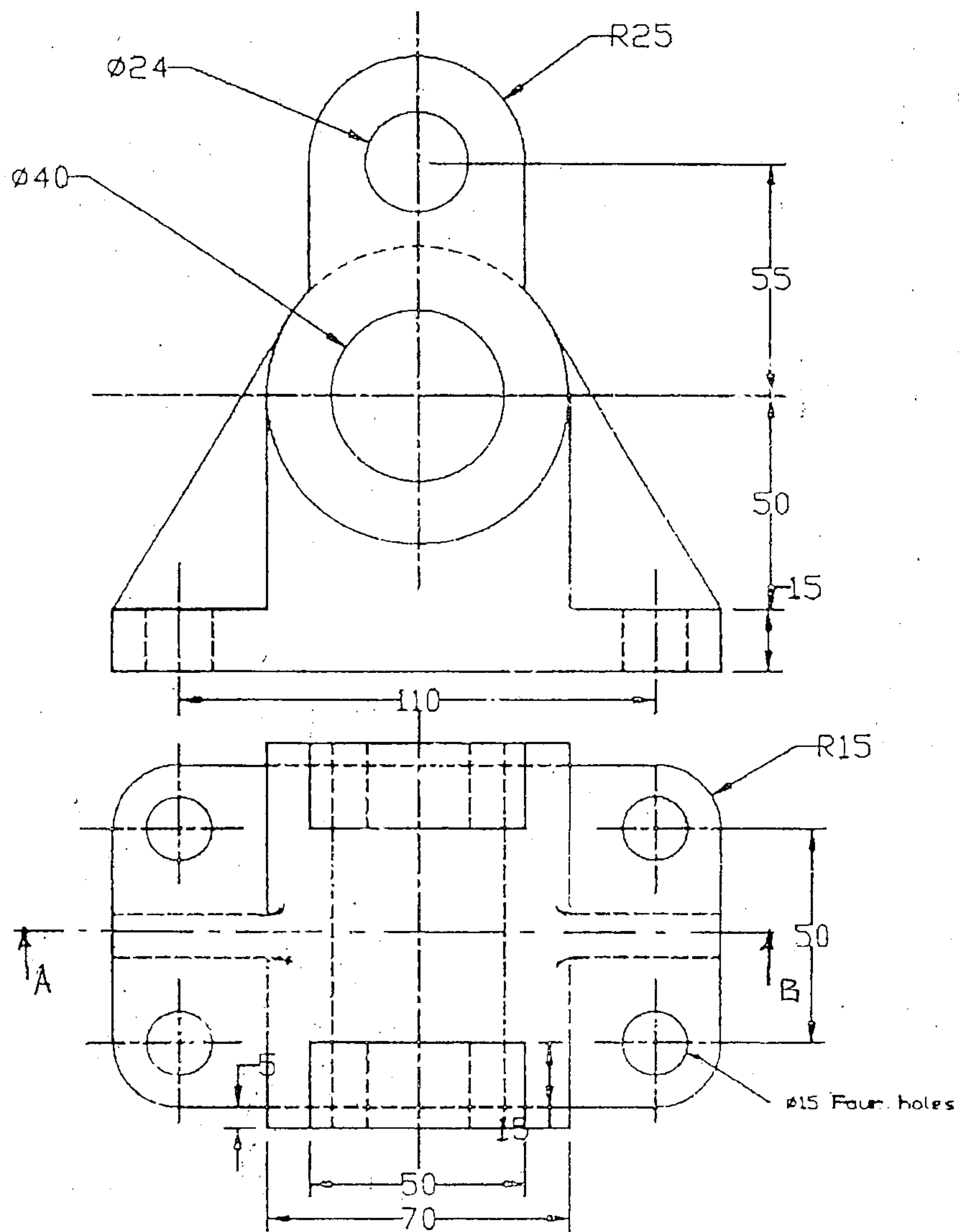

[TURN OVER]

- Q2 Fig. shows isometric view of a block. Draw sectional front view section A-A, 15
Top view and Left hand side view

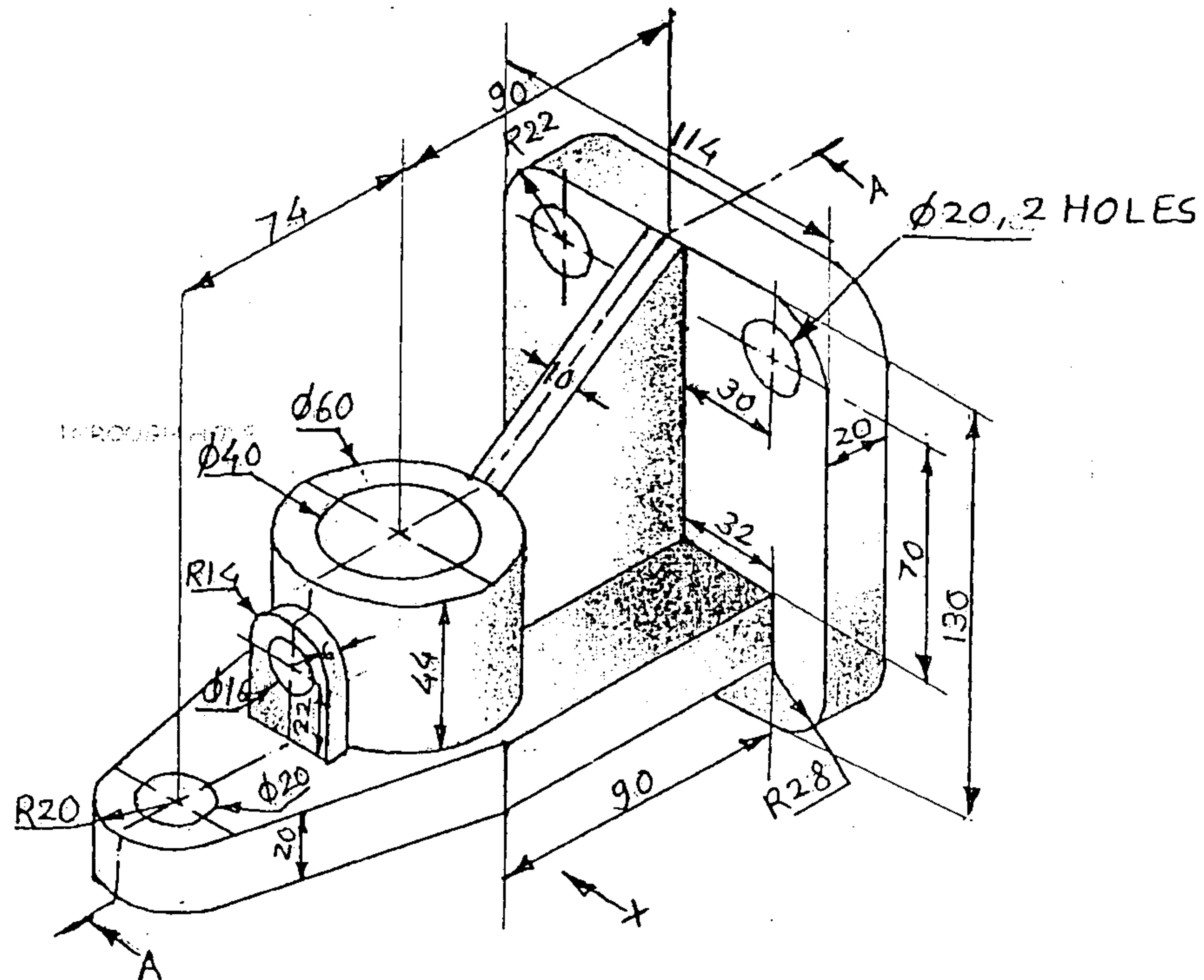

- Q3 a The distance between the end projectors of a line is 50 mm. One end is 15mm 8
above HP and 20 mm in front of VP while the other end is 40 mm below HP
and 30 mm behind VP. Draw projections of the line and find the true Length
and inclinations of the line with HP and VP.
- b A disc of diameter 50mm is rolling without slipping along a straight line. Draw 7
the locus traced by the point which is common to disc and line when the disc
completes one revolution. Name the curve.
- Q4 A right circular cone of diameter 60mm and the axis 75mm is lying on HP on 15
one of its end generators. Draw projections of the cone when the plane
containing the axis and the end generator is inclined 45 degrees to VP with its
Apex being away from the observer.
- Q5 a Pentagonal pyramid of base edge 40mm and axis 65mm is resting on HP with 12
an edge of base is parallel to VP and near to it. It is cut by a section plane
inclined 45 degrees to HP and passing through a point 25 mm above base on
the axis. Draw the Front View, Sectional Top View and True shape of the
section.

[TURN OVER

- b Draw free Hand sketches of the following.(Two views) 3
- a) Hexagonal headed Bolt
- b) Castle Nut.
- Q6 Right circular cylinder of diameter 60 mm and axis 70 mm is resting on HP on its base. It is cut by a section plane inclines 60 degrees to HP and passes through a point 25 mm from the top surface, on the axis. Draw the projections and develop the lateral surface of the retained portion of the cylinder. 15
- Q7 a Draw the Isometric View of the Two view given using natural Scale. 12

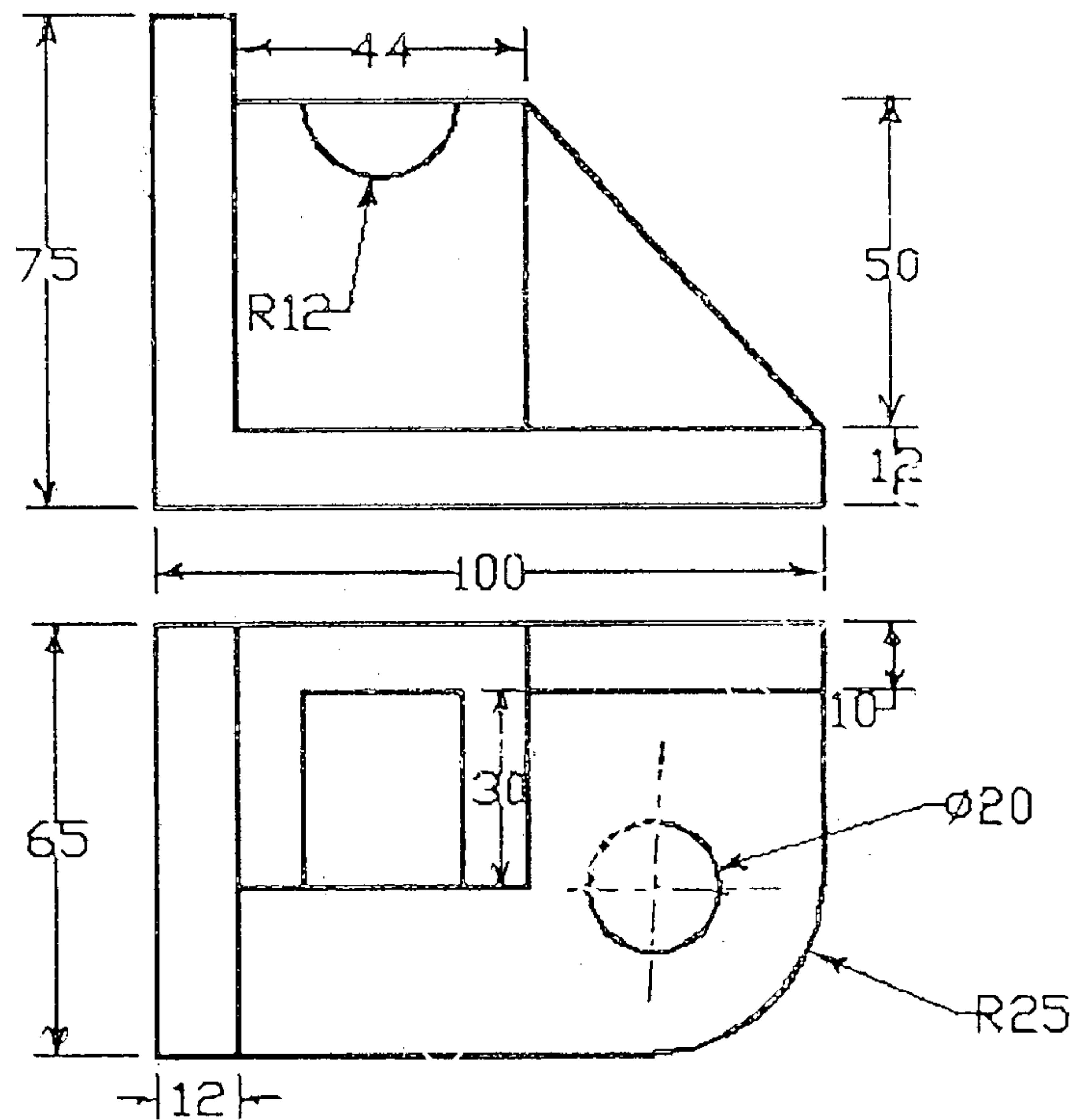

- b Draw free Hand sketches of the following (Two views) 3
- a) Square Nut
- b) Rag Foundation Bolt

(OLD COURSE)

QP Code : MV-17746

(3 Hours)

[Total Marks : 100

- N.B. : (1) Question No. 1 is compulsory.
(2) Attempt any four out of the remaining six questions.
(3) Assume any suitable data, wherever required.

1. (a) Explain features of Java. 4
(b) Explain conditional operators in Java. 4
(c) Write expected output of following 4
class substringcons {
public static void main (String args[]) {
byte ascii [] = { 65, 66, 67, 68, 69, 70 } ;
String s₁ = new String (ascii) ;
System.out.println (s₁) ;
String s₂ = new String (ascii, 2, 3) ;
System.out.println (s₂) ;
}
} 4
(d) Explain lifecycle of thread. 4
(e) Create an Applet that displays "All the Best". 5
2. (a) Write a program to accept student names from the command line and store them in vector. 5
(b) Explain inability of multiple inheritance in java and the alternative way to achieve it with example. 5
(c) Write short note on : Passing parameter to Applet. 5
(d) Write a program to accept a number from command line and print the sum of cube of individual digits. 5
3. (a) Write a program to display following pattern :—
*
* * *
* * * * * 5
(b) Explain the difference between default and public access specifier in Java. 5
(c) With the help of suitable program describe final methods and classes. 5
(d) Write a program to demonstrate packages in Java. 5
4. (a) Explain static members with example. 5
(b) Write short note on Wrapper classes. 5

[TURN OVER

- (c) Explain method overriding with example. 5
5. (a) Write a program to find GCD of two numbers. 5
- (b) Explain exception handling with example. 5
- (c) Explain isAlive (), join (), and sleep () Methods. Write a program to illustrate use of these methods. 5
6. (a) Write a program to find area of a circle. 5
- (b) Write a program to find smallest of 'n' numbers taken from the user. 10
- (c) Write a program to accept and display the month number. Throw a Number Format Exception if improper month number is entered. 5
7. (a) Write a program that demonstrates call by value to swap two numbers. 5
- (b) What is a vector ? How is it different from an array ? 5
- (c) Write a program to demonstrate method overloading by overloading the Methods for calculating area of circle, rectangle, and triangle. 5
- (d) What is a package ? How do we design a package in Java ? State applications of packages.

(OLD COURSE)QP Code : **MV-17726**

(3 Hours)

[Total Marks : 100

- N. B. :** (1) Question No. 1 is **compulsory**.
 (2) Attempt any **four** questions from the remaining six questions.
 (3) **Figures** to the right hand side indicate **full marks**.

1. (a) Solve $(2D^2 + 5D - 12)y = 0$ 3
 (b) Evaluate $\int_0^{\infty} x e^{-x^4} dx$ 3
 (c) Evaluate $\int_0^1 \int_{x^2}^x xy(x+y) dy dx$ 3
 (d) Evaluate $\int_0^1 \sqrt{1-x^4} dx$ 3
 (e) If $B(n,3) = \frac{1}{105}$ find 'n' where n is +ve integer. 4
 (f) Using Euler's method find approximate value of y at x=1 in five steps taking n = 0.2. Given $\frac{dy}{dx} = x+y$ and $y(0) = 1$. 4
2. (a) Prove that $\int_0^3 \frac{x^{\frac{3}{2}}}{\sqrt{3-x}} dx \cdot \int_0^1 \frac{dx}{\sqrt{1-x^4}} = \frac{432}{35} \pi$ 6
 (b) Solve $(D^2 - D + 1)Y = \cos 2x$. 6
 (c) Solve the differential equation $\frac{dy}{dx} = xy$ with initial conditions $y(1) = 2$ and find y at (i) $x = 1.2$ (ii) $x = 1.4$. By Runge-Kutta method of Fourth order. 8
3. (a) In a circuit containing inductance, L, resistance R, voltage E, the current I, is given by $L \frac{dI}{dt} + RI = E$, find current I at time t if at $t = 0$, $I = 0$ and L, R, E are constant. 6
 (b) Find the length of the astroid $x = a \cos^3 t$, $y = a \sin^3 t$ 6
 (c) Solve $\frac{d^2y}{dx^2} - 4 \frac{dy}{dx} + 4y = x^2 + e^x + \cos^2 x$ 8

[TURN OVER

Con. 9418-14.

4. (a) Evaluate $\int_0^a \int_0^a \int_0^a (yz + zx + xy) dx dy dz$ 6

(b) Find the volume bounded by the cone $z^2 = x^2 + y^2$ and the paraboloid; 6

$$z = x^2 + y^2$$

(c) Apply the method of variation of parameters to solve 8

$$(D^2 - 2D + 2)y = e^x \tan x.$$

5. (a) Solve using Taylor's series method the differential equation $\frac{dy}{dx} = x + y$ start 6

from $x = 1, y = 0$ and carry to $x = 1.2$ with $h = 0.1$

(b) Find by double integration the area of the cardioid $r = a(1 + \cos \theta)$ 6

(c) Change the order of integration and evaluate 8

$$\int_0^a \int_{\frac{x}{a}}^{2a-x} xy \, dy \, dx$$

6. (a) Change to polar co-ordinates and evaluate 6

$$\int_0^a \int_y^a \frac{x^2}{\sqrt{x^2 + y^2}} dx \, dy$$

(b) Find the length of the cardioid $r = a(1 - \cos \theta)$ which lies outside the circle 6

$$r = a \cos \theta.$$

(c) Prove that $B(m, n) = \frac{\Gamma(m) \Gamma(n)}{\Gamma(m+n)}$ 8

7. (a) Solve $(x^2 + y^2 + 1) dx - 2xy dy = 0$ 6

(b) Solve $\frac{dy}{dx} = x^3 y^3 - xy$ 6

(c) Solve $(D^2 + 2)y = e^x \cos x + x^2 e^{3x}$ 8

F-E sem II old M-2014

sub- AP-II

21/5/14

QP Code : MV-17732

(OLD COURSE)

(2 hours)

[Total Marks : 75

- N.B. (1) Question No. 1 is **compulsory**.
(2) Attempt any **four** questions from Q. No. 2 to 7.
(3) **Figures** to the **right** indicate **full** marks.
(4) Use **suitable** data whenever **necessary**.

1. Attempt any **five** from the following :— 15
- (a) Why electron microscope is consider much more powerful than optical microscope ?
 - (b) Define relative permiability and suceptibility. Write the relation between them.
 - (c) How number of primary maxima (n) depends on number of lines/cm (N) on the grating and how it affects its R.P.
 - (d) Calculate de-broglie's wave length of electron whose K.E. is 120 ev
[$m_e = 9.1 \times 10^{-31}$ kg, $h = 6.33 \times 10^{-34}$ J. sec].
 - (e) What is the difference between critical angle and acceptance angle ?
 - (f) How thin film interference is used to test optical flatness of glass plate ?
 - (g) What paricular spectra would be absent, when width of opacity is double of the transparency in a grating ?
2. (a) Derive the constructive and destructive iuterference conditions for parallel thin film. 8
(b) Explain the terms metastable state, pumping and population inversion and how they are related to the laser action in He-Ne laser with proper energy level diagram. 7
3. (a) By explaning de-broglie's hypothesis, develop one dimensional time dependent Schrodinger wave quation for matter wave. 8
(b) Explain magnetic-circuit, consider an air core tosoid with 500 turns, with a cross-section of 6 cm^2 , mean radius 15 cm and coil current 4 amp. Now calculate mmf (NI.), reluctance(R.), M-flux(ψ), M-flux density(B) and M-field intensity(H). 7
4. (a) Differentiate between step index and graded index fiber and calculate N.A for step index fiber. 5
(b) Differentiate between photography and holography. Explain construction at reconstruction of hologram. 5
(c) A magnetic material has an intensity of 198 A/m and magnetisation of 2300 A/m. Calculate M-flux density and relative permiability. 5
5. (a) What is Rayleigh, criterion of resolution for diffraction ? Derive the expression for R.P. of grating by explaining each term. 5

[TURN OVER

- (b) Newton's rings are observed with wave length 5×10^{-5} cm. The diameter of 10th dark ring is 0.5 cm. Calculate the radius of curvature R and thickness (t) of the film at the 10th dark ring. 5
- (c) What are hard and soft magnetic materials ? Write their characteristic properties and applications. 5
6. (a) Explain the working principle of diffusion pump by mentioning the order of vacuum it can achieved. 5
- (b) A monochromatic light from He-Ne laser 6328 \AA falls normally on a diffraction grating having 1000 lines/cm. Find the maximum orders possible and calculate the angle of diffraction for 2nd order spectral line. 5
- (c) Prove that electron can not stay within nucleus of radius 10^{-15} m. 5
7. Write short notes on any **three** of the following :- 15
- (a) SEM
 - (b) Antiflecting film
 - (c) Pirani gauge
 - (d) Mention some important changes takes place in material at nano-scale.
-

(OLD COURSE)

QP Code : MV-17738

(2 Hours)

[Total Marks :75

- N.B.** (1) Question No 1 is compulsory.
(2) Solve any four questions from the remaining six.
(3) All questions carry equal marks.
(4) Atomic weights: H= 1, C=12, N=14, Na=23, Mg=24, S=32, Cl=35.5, Ca=40.

1. Solve any **five** from the following : - 15
- (a) What is electrochemical corrosion ?
 - (b) Write a note on mining of crude petroleum oil.
 - (c) How composite material is classified ?
 - (d) Explain 'prevention of waste' principal in green chemistry.
 - (e) Explain carbon membrane.
 - (f) Give composition, properties and applications of Commercial brass.
 - (g) 0.5 grams of coal sample was burnt in Bomb calorimeter. The ash formed was extracted with acid & extract obtained was treated with BaCl_2 solution to get BaSO_4 PPT. The weight of dry precipitate was 0.05 grams Calculate % of Sulphur.
2. (a) A sample of coal was analyzed as follows 1.00 gram of coal sample was weighed in silica crucible. After heating coal sample for 1 hour at $110-120^\circ\text{C}$. The dry residue weighed 0.985 grams. The Crucible was covered with lid & heated strongly for 7 minutes at 950°C . The residue weighed was 0.800 grams. The crucible was then heated until constant weight was obtained. The last residue was found to weigh 0.100 grams find results of proximate analysis. 6
- (b) Explain effect of following factors affecting rate of corrosion 5
- (i) Temperature
 - (ii) Cathodic & anodic area
 - (ii) Nature of films
- (c) Explain composition, properties, advantages & disadvantages of stainless steel. 4
3. (a) Explain impressed current method for the prevention of electrochemical corrosion & write How it is different from sacrificial method ? 6
- (b) What is fractional Distillation? Explain minimum four fractions in detail. 5
- (c) Explain composition, properties & applications of Duralumin. 4

[TURN OVER

4. (a) A sample of coal contained C= 60%, O=32%, S= 0.2% N= 0.4% H=7% & ash=0.4%. Calculate GCV & NCV for given coal sample. 6
- (b) Define composite materials & write a note on fiber reinforced composite material. 5
- (c) Calculate % of atom economy for the following reaction : 4

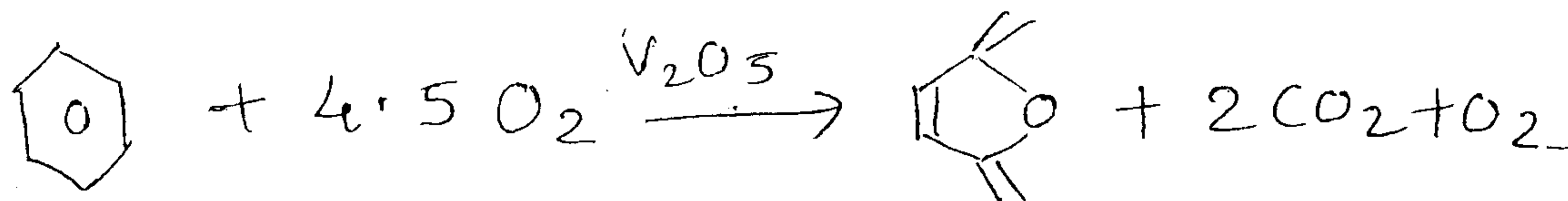

5. (a) Define catalyst, Discuss various types of catalyst & also mention the ideal characteristics of Catalyst 6
- (b) What is paint ? Explain various constituents of paints. 5
- (c) Write a note on oxide ceramic powder Alumina. 4
6. (a) State & Explain 12 principals of Green Chemistry with suitable examples. 6
- (b) What is catalysis ? Describe various types with suitable examples. 5
- (c) Write a note on Intergranular corrosion. 4
7. (a) Explain adsorption theory of heterogeneous catalysis. 6
- (b) Explain catalytic cracking & write advantages of catalytic cracking over thermal cracking. 5
- (c) Draw neat labeled diagram for laminar & sandwich panel. 4

F.E. sem II old m-2014
sub- CS.

(OLD COURSE)

QP Code : **MV-17750**

(2 Hours)

[Total Marks : 75

N.B. (1) Question No. 1 is **compulsory**.

(2) Attempt any **four** from the remaining **six** questions.

(3) Figures to the **right** indicate marks.

(3) Answers to all sub questions should be attempted and grouped **together**.

1. (a) Distinguish between oral and written communication and explain any four oral attributes with examples. 10
(b) Explain any two principles of business correspondence 5
2. Write short notes on any THREE of the following: 15
(a) Visual aids
(b) Any five guidelines for effective reading
(c) Importance of feedback
(d) Layout of complete block form
3. (a) Write to Punjab National Bank, Agra to make enquiries about your interest in opening an account, and asking for documents required. Identify the necessary details. (Use block form) 9
(b) Study the following statements about the process of communication and state whether **true** or **false** : 6
(i) Symbolic action is limited to Verbal communication
(ii) Tightened jaws and stiff face muscles are signs of aggressiveness
(iii) The process of communication begins when the sender converts the idea into words or gestures
(iv) The main objective of horizontal communication is developing team work and promoting group coordination within an organization
(v) The responses of the receiver creates feedback
(vi) Oral communication is effective to convey lengthy messages
4. (a) Out of 12 boxes that you have received from your suppliers 04 contained goods that you did not order. Draft a complaint about asking for its quick replacement. 9
(b) Write a brief note with an example on each of the following :— 6
(i) Salutation
(ii) Date line
(iii) Signature Block
5. (a) Describe any **one** of the following objects : 8
(i) Telescope
(ii) Micrometer
(iii) Printer

[TURN OVER

- (b) Rewrite the following sentences making them more effective :— 2
- (i) If highly polished you may slip on the floor.
- (ii) At 40clock yesterday she reluctantly attended the meeting.
- (c) Give one word substitutes for the phrases given below :— 5
- (i) Incapable of being burnt—————
- (ii) One who feeds on human flesh—————
- (iii) Radical change in government—————
- (iv) The scientific study of industrial art—————
- (v) Haphazard without order—————
6. (a) Match the following: 3
- | | |
|-------------------------------|------------------|
| (i) Indented paragraph | HCL!ESTB/2014/09 |
| (ii) Logo | Barrier |
| (iii) Reference no | Verbal |
| (iv) Communication with words | Letter head |
| (v) Block in communication | Semi block form |
| (vi) Leaning backward | Relaxed |
- (b). Write short notes on :— 4
- (i) Signs and symbols
- (ii) Status as a psychological barrier
- (c) Define warning and danger with an example for each. 3
- (d) List any five instructions to follow while operating a welding machine. 5
7. Read the following passage and answer the questions given below :—
- Marie Curie was one of the most accomplished scientists in history. Together with her husband, Pierre, she discovered radium, an element widely used for treating cancer, and studied uranium and other radioactive substances. Pierre and Marie's amicable collaboration later helped to unlock the secrets of the atom.
- Marie was born in 1867 in Warsaw, Poland, where her father was a professor of physics. At an early age, she displayed a brilliant mind and a blithe personality. Her great exuberance for learning prompted her to continue with her studies after high school. She became disgruntled, however, when she learned that the university in Warsaw was closed to women. Determined to receive a higher education, she defiantly left Poland and in 1891 entered the Sorbonne, a French university, where she earned her master's degree and doctorate in physics.

[TURN OVER

Marie was fortunate to have studied at the Sorbonne with some of the greatest scientists of her day, one of whom was Pierre Curie. Marie and Pierre were married in 1895 and spent many productive years working together in the Physics laboratory. A short time after they discovered radium, Pierre was killed by a horse-drawn wagon in 1906. Marie was stunned by this horrible misfortune and endured heartbreaking anguish. Despondently she recalled their close relationship and the joy that they had shared in scientific research. The fact that she had two young daughters to raise by herself greatly increased her distress.

Curie's feeling of desolation finally began to fade when she was asked to succeed her husband as a Physics professor at the Sorbonne. She was the first woman to be given a professorship at the world famous university. In 1911 she received the Noble Prize in chemistry for isolating radium. Although Marie Curie eventually suffered a fatal illness from her long exposure to radium, she never became disillusioned about her work. Regardless of the consequences, she had dedicated herself to science and to revealing the mysteries of the physical world.

- (i) The Curies' _____ collaboration helped to unlock the secrets of the atom. 1
- A. friendly
 - B. competitive
 - C. courteous
 - D. industrious
 - E. chemistry
- (ii) Marie had a bright mind and a _____ personality. 1
- A. strong
 - B. lighthearted
 - C. humorous
 - D. strange
 - E. envious
- (iii) State any two achievements of Curie. 2
- (iv) What prompted Curie to pursue higher education? 2
- (v) State the reasons for Curie's distress. 2
- (vi) Summarize the passage in about 100 words with a suitable title. 7